

ALUMINUM AND COPPER
BUS BARS INSERT

REVISION		
NO.	DESCRIPTION	BY
1	PRELIMINARY	BTL
2	RELEASED FOR FABRICATION	BTL

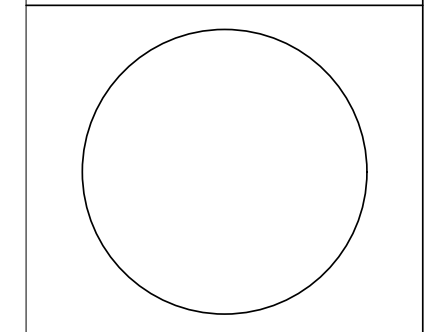

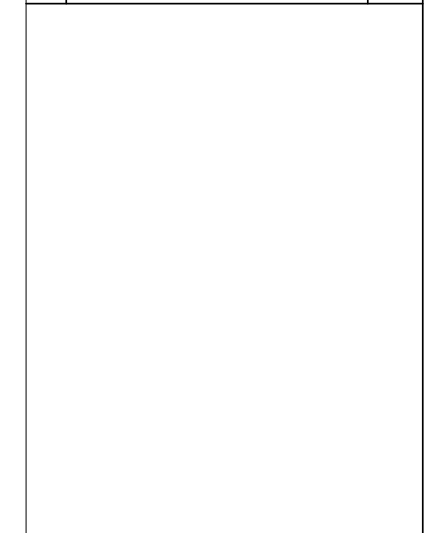

BRENDAN STANTON, INC.
ELECTRICAL CONTRACTOR
416 STUMP ROAD
 MONTGOMERYVILLE, PA 18936
 PH:(215)699-7700-FAX:(215)699-7785
 Email Address: info@bsielectric.com
 Webpage Address: www.bsielectric.com

PROJECT NAME:
**NRC
 HEAF TESTING**

DRAWING TITLE:
SNL BOX TESTING

DRAWING NO: **B01-113317-19A-M1** SHEET NO: **M1**

DWN:	BTL	08/21/2019
CKD:	ROT	09/04/2019
APP:		

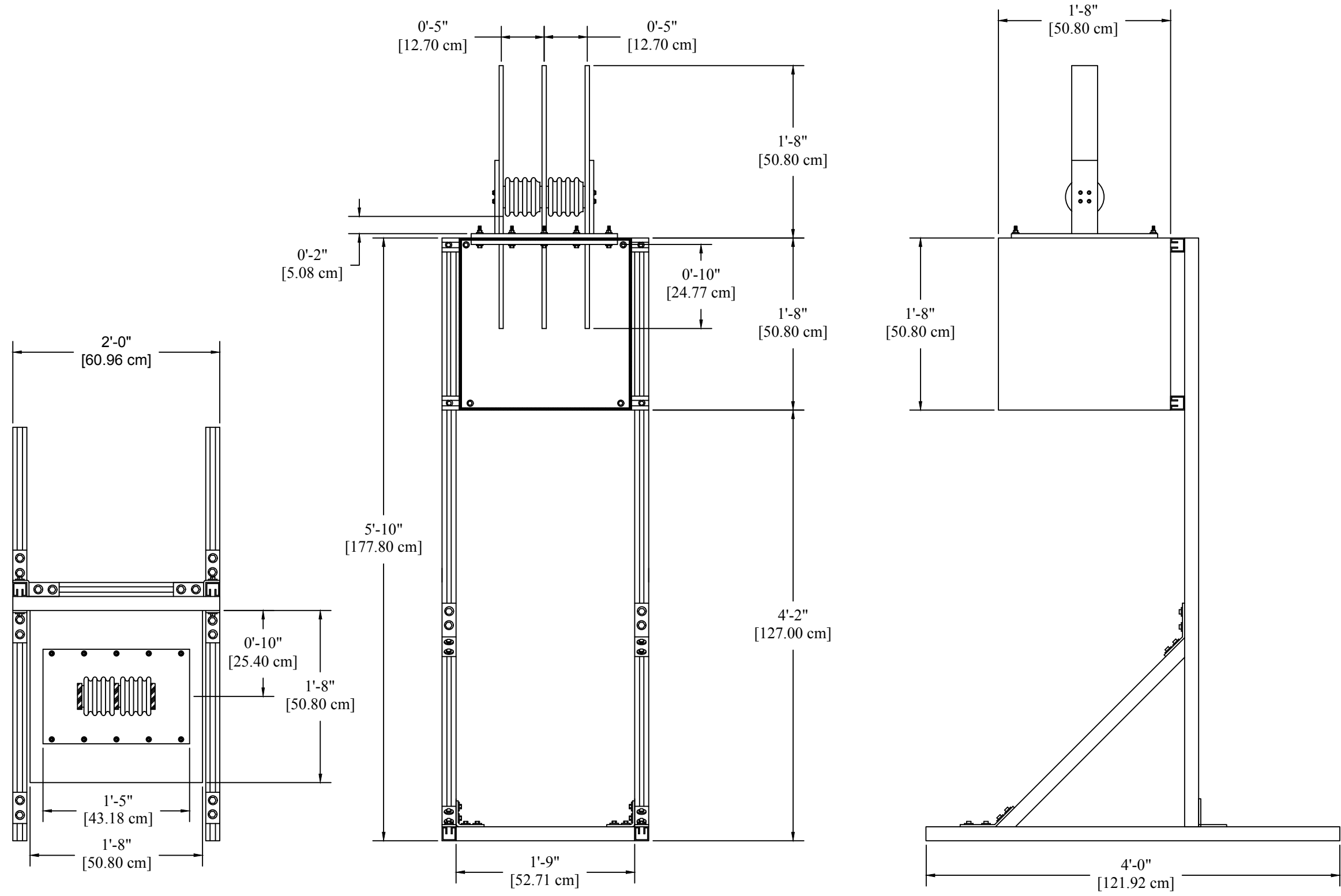

REVISION		
NO.	DESCRIPTION	BY
1	PRELIMINARY	BTL
2	RELEASED FOR FABRICATION	BTL

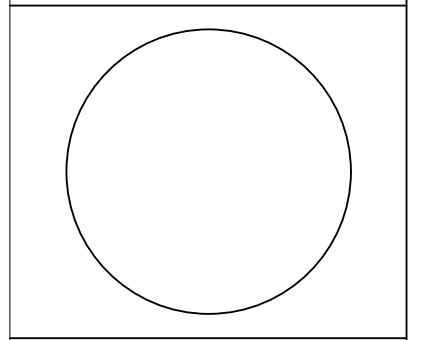
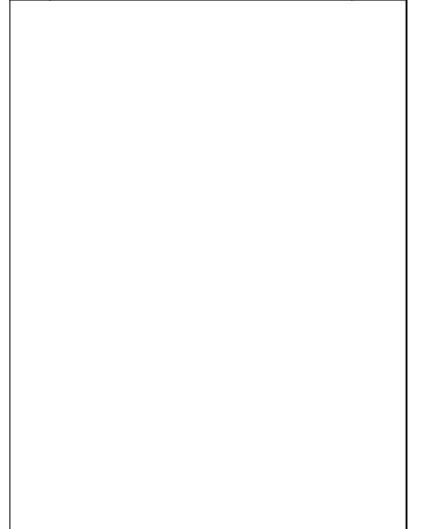



BSITM
 Electrical
 Electronic
 Contractors
BRENDAN STANTON, INC.
ELECTRICAL CONTRACTOR
 416 STUMP ROAD
 MONTGOMERVILLE, PA 18936
 PH: (215) 699-7700 FAX: (215) 699-7785
 Email Address: info@bsielec.com
 Webpage Address: www.bsielec.com

PROJECT NAME:
**NRC
 HEAF TESTING**

DRAWING TITLE:
**SNL BOX TESTING
 BUS BARS INSERT
 DETAIL DIMENSIONS**

DRAWING NO: B01-113317-19A-M3	SHEET NO: M3
----------------------------------	-----------------

DWN:	BTL	08/21/2019
CKD:	ROT	09/04/2019
APP:		

REVISION		
NO.	DESCRIPTION	BY
1	PRELIMINARY	BTL
2	RELEASED FOR FABRICATION	BTL

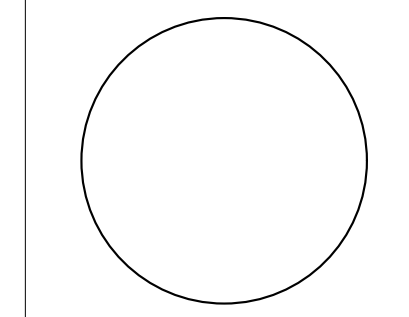
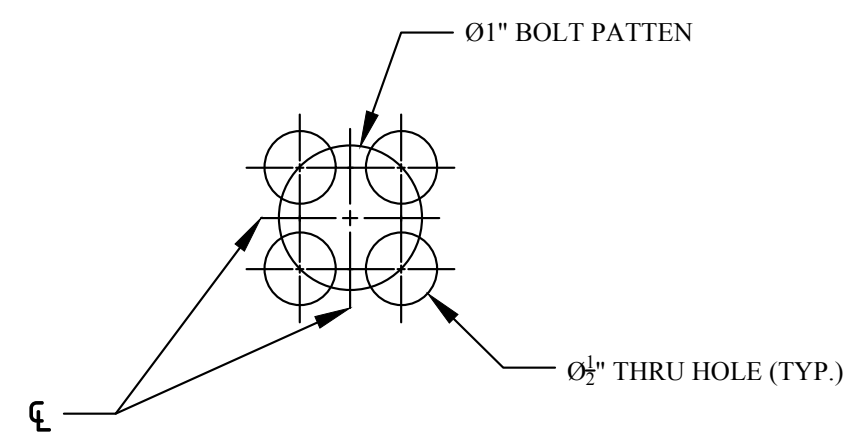
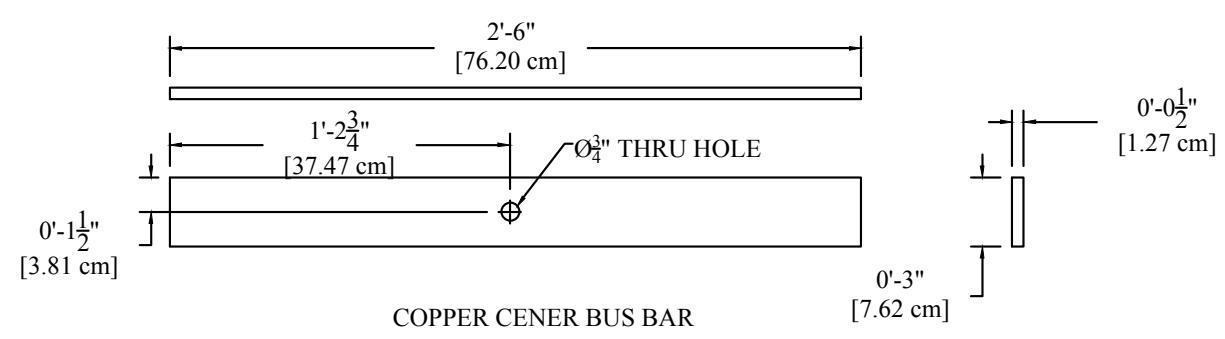
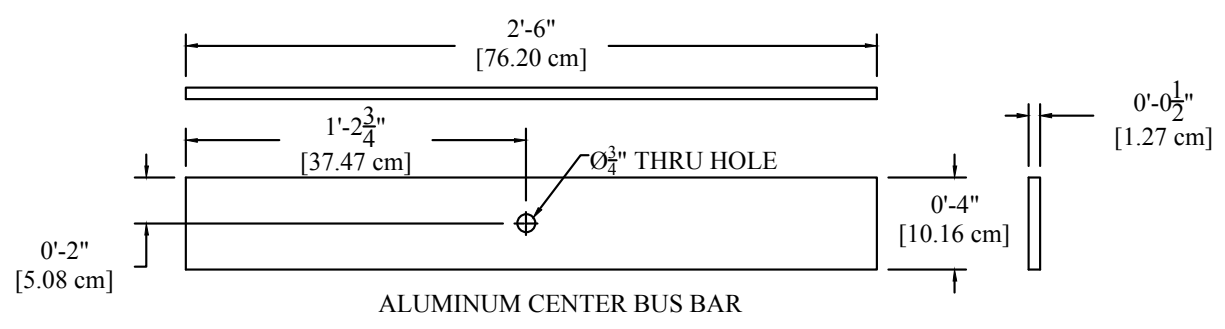
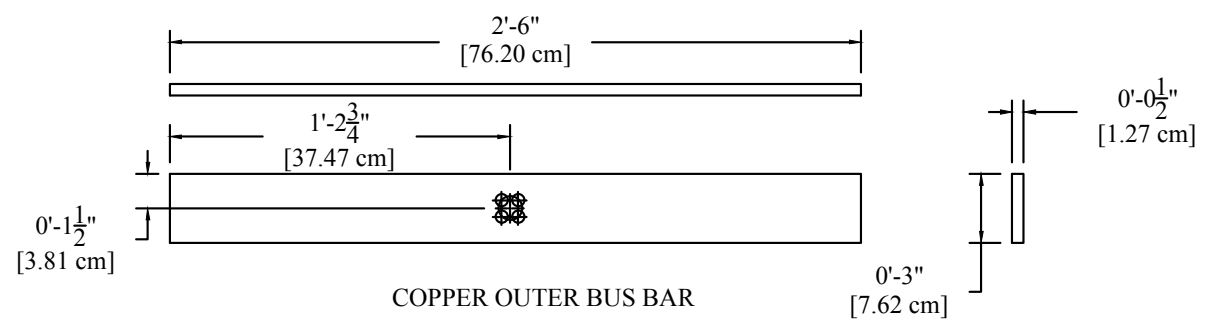
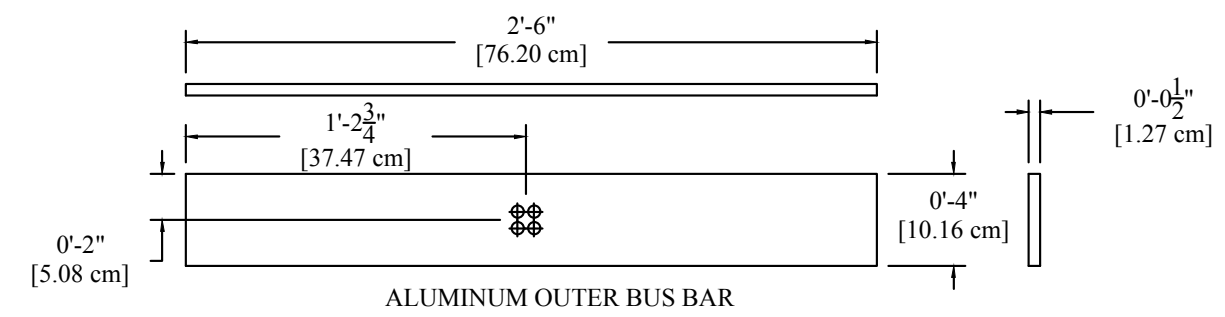

BSITM
 Electrical
 Electronic
 Contractors

BRENDAN STANTON, INC.
 ELECTRICAL CONTRACTOR

416 STUMP ROAD
 MONTGOMERYVILLE, PA 18936
 PH: (215) 699-7700 FAX: (215) 699-7785
 Email Address: info@bsielectric.com
 Webpage Address: www.bsielectric.com

PROJECT NAME:
**NRC
 HEAF TESTING**

DRAWING TITLE:
**SNL BOX TESTING
 BUS BARS
 DETAIL DIMENSIONS**

DRAWING NO: B01-113317-19A-M4 SHEET NO: **M4**

DWN:	BTL	08/21/2019
CKD:	ROT	09/04/2019
APP:		

REVISION		
NO.	DESCRIPTION	BY
1	PRELIMINARY	BTL
2	AS TESTED	BTL

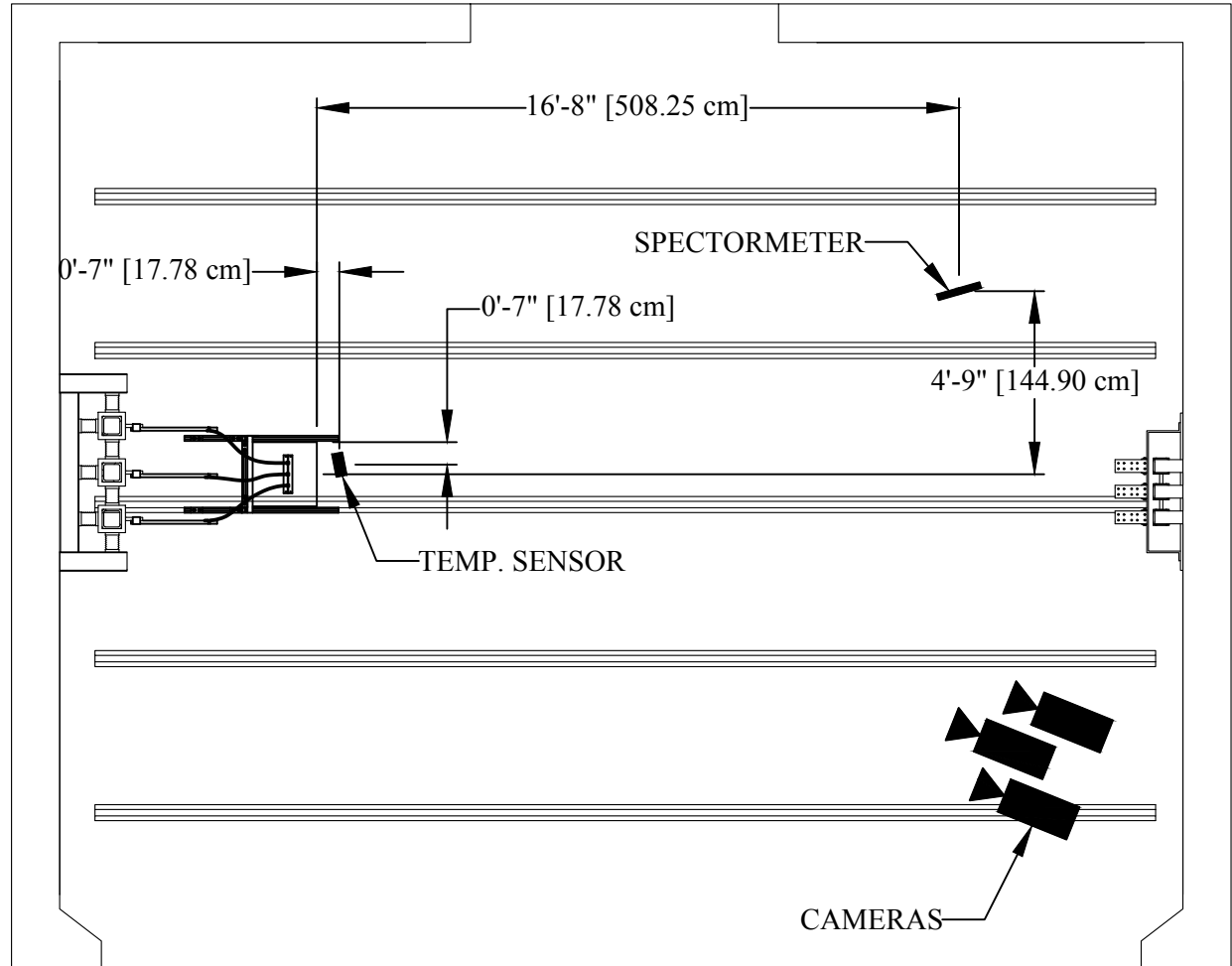

TOP VIEW

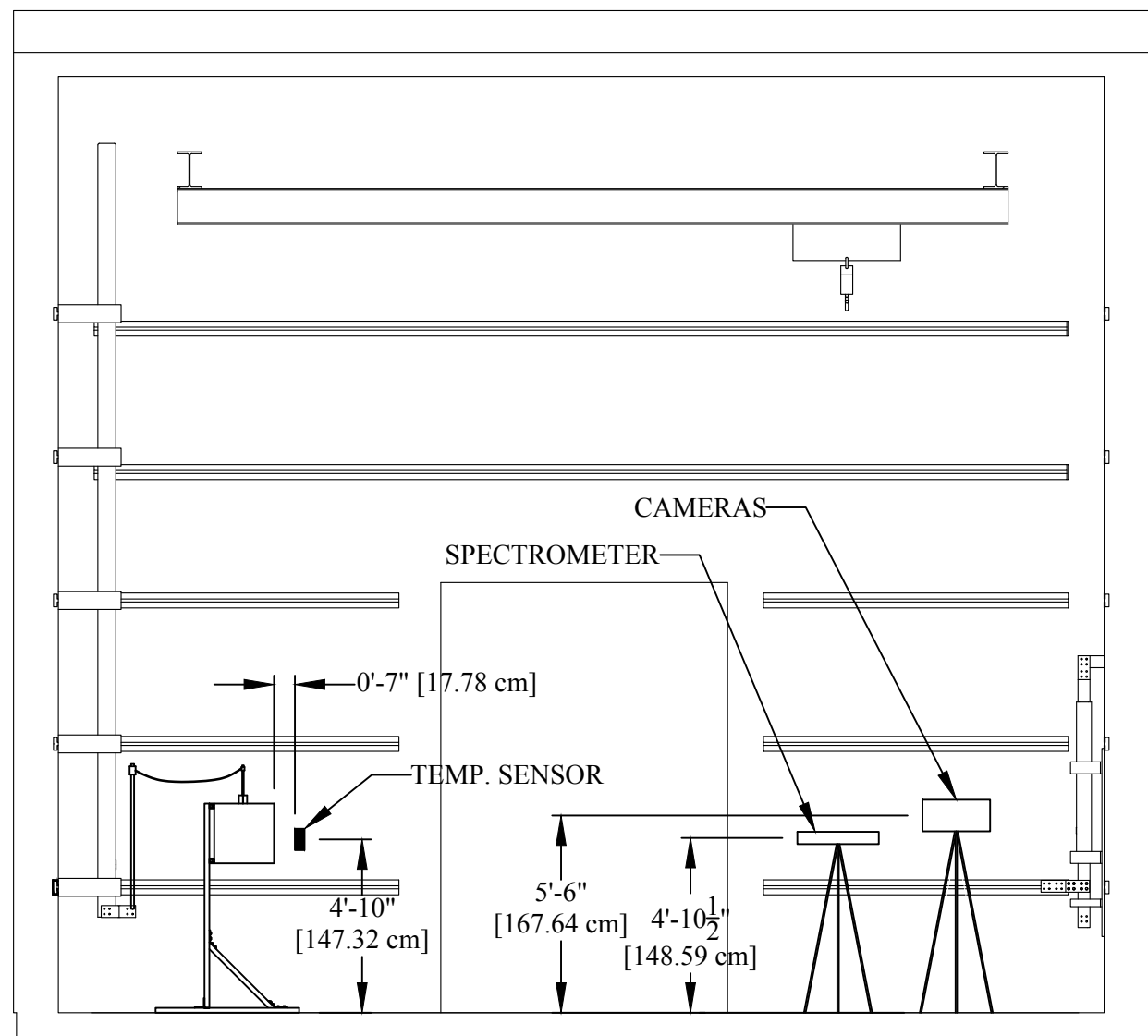

FRONT VIEW

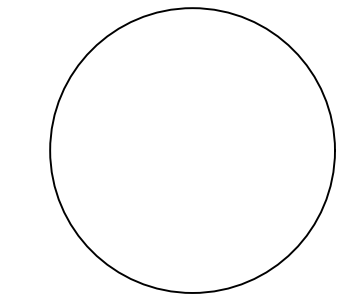

BSITM
 Electrical
 Electronic
 Contractors

BRENDAN STANTON, INC.
 ELECTRICAL CONTRACTOR

416 STUMP ROAD
 MONTGOMERYVILLE, PA 18936
 PH: (215) 699-7700 FAX: (215) 699-7785
 Email Address: info@bsielectric.com
 Webpage Address: www.bsielectric.com

PROJECT NAME:
**NRC
 HEAF TESTING**

DRAWING TITLE:
**1kV, 1kA TESTING
 SNL BOX
 SETUP CONFIGURATION**

DRAWING NO: B01-113317-19A-T1	SHEET NO: T1
DWN: BTL	08/21/2019
CKD:	
APP:	